

## Latches

**Stainless Steel, Operating Side in Hygienic Design (Front Hygiene) / Operating and Latch Arm Side in Hygienic Design (Full Hygiene)**

### SPECIFICATION

#### Type

- Type **SW**: With two spanner flats

#### Coding

- Version **FH**: Operating side in Hygienic Design (front hygiene)
- Version **VH**: Operating and latch arm side in Hygienic Design (full hygiene)

Lock housing

Stainless steel AISI 316L

Latch arm

Stainless steel

- AISI 304 for  $d_1 = 22$  (front hygiene)
- AISI 316L for  $d_1 = 30$  (front hygiene)
- AISI 316 (full hygiene)

Seals (full hygiene)

Blue, FDA compliant

Temperature resistant  $-40\text{ °C}$  to  $+110\text{ °C}$

Sealing ring / O-ring

EPDM **E**

- Blue, FDA compliant (front hygiene)
- Temperature resistant  $-40\text{ °C}$  to  $+120\text{ °C}$
- Hardness  $85 \pm 5$  Shore A (Sealing ring)
- Hardness  $70 \pm 5$  Shore A (O-ring)
- Other Seals / Wiper (full hygiene) TPU, Hardness  $95 \pm 5$  Shore A

Other parts

Stainless steel AISI 316L

All moving parts lubricated with FDA compliant special grease

Protection class IP 66

### INFORMATION

Stainless steel latches GN 1150 are intended for use in hygienic areas and meet hygiene requirements on the operating side (front hygiene) and on the operating and latch arm side (full hygiene) due to the special mounting nuts as well as the optimized latch arm and hexagon head screw. The locking mechanism is protected by two seals (front hygiene) and multiple seals (full hygiene). At the same time, the high surface quality ( $R_a < 0.8\text{ }\mu\text{m}$ ) and dead-space-free mounting prevent dirt from adhering and facilitate cleaning.

The latches create a secure closure by rotating a maximum of  $90^\circ$ , which positions the latch arm in the locked position behind the frame. Slanted surfaces on the latch arm ensure smooth positioning. Latch arms are available with different bend angles to cover a latch arm distance A from 6 to 28 mm (front hygiene) and 22 to 44 mm (full hygiene).

The mounting holes in the housing must be at a right angle, free of burrs and without a chamfer. This ensures that the sealing rings will function properly. Stainless steel latches GN 1150 (front hygiene) are supplied with loosely enclosed latch arm.



### ACCESSORY

- Sealing Rings GN 7600 (see page )
- Socket Keys GN 1151 (see page )

### TECHNICAL INFORMATION

- IP Protection Classes (see page A23)
- Plastic Characteristics (see page A2)
- Stainless Steel Characteristics (see page A26)

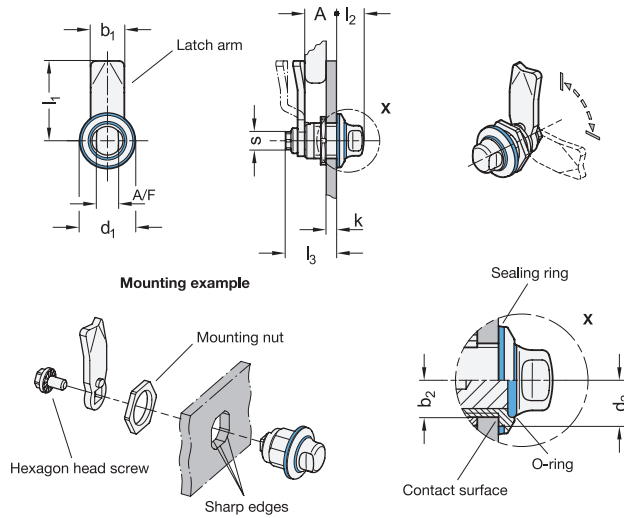

GN 1150-FH

STAINLESS STEEL

Description	d1	Latch arm distance A	b1	b2	d2	k Min.	k Max.	l1 ±1	l2	l3 ≈	s	A/F	⚖
GN 1150-22-SW-7,5-FH-E	22	7,5	12	7	9	1,5	5	24	12,6	21	8	9	44
GN 1150-22-SW-13,5-FH-E	22	13,5	12	7	9	1,5	5	24	12,6	21	8	9	44
GN 1150-22-SW-19,5-FH-E	22	19,5	12	7	9	1,5	5	24	12,6	21	8	9	44
GN 1150-30-SW-6-FH-E	30	6	19	10	13	1,5	6	45	15,3	29	10	13	125
GN 1150-30-SW-10-FH-E	30	10	19	10	13	1,5	6	45	15,3	29	10	13	125
GN 1150-30-SW-14-FH-E	30	14	19	10	13	1,5	6	45	15,3	29	10	13	125
GN 1150-30-SW-18-FH-E	30	18	19	10	13	1,5	6	45	15,3	29	10	13	125
GN 1150-30-SW-20-FH-E	30	20	19	10	13	1,5	6	45	15,3	29	10	13	125
GN 1150-30-SW-22-FH-E	30	22	19	10	13	1,5	6	45	15,3	29	10	13	125
GN 1150-30-SW-24-FH-E	30	24	19	10	13	1,5	6	45	15,3	29	10	13	125
GN 1150-30-SW-26-FH-E	30	26	19	10	13	1,5	6	45	15,3	29	10	13	125
GN 1150-30-SW-28-FH-E	30	28	19	10	13	1,5	6	45	15,3	29	10	13	125

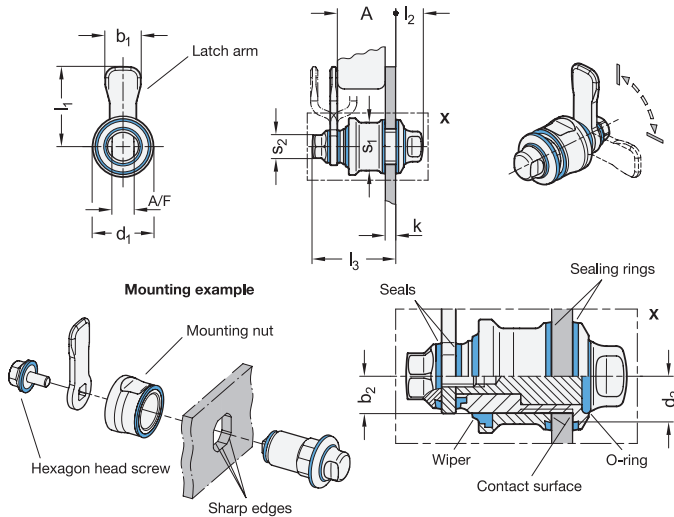

GN 1150-VH

STAINLESS STEEL

Description	d1	Latch arm distance A	b1	b2	d2	k Min.	k Max.	l1 ±1	l2	l3	s1	s2	A/F	⚖
GN 1150-22-SW-24-VH-E	22	24	14	7	9	1,5	5	30	12,6	39,5	19	11	9	83
GN 1150-22-SW-30-VH-E	22	30	14	7	9	1,5	5	30	12,6	39,5	19	11	9	83
GN 1150-22-SW-36-VH-E	22	36	14	7	9	1,5	5	30	12,6	39,5	19	11	9	83
GN 1150-30-SW-22-VH-E	30	22	20	10	13	1,5	6	45	15,3	47	27	13	13	211
GN 1150-30-SW-33-VH-E	30	33	20	10	13	1,5	6	45	15,3	47	27	13	13	211
GN 1150-30-SW-44-VH-E	30	44	20	10	13	1,5	6	45	15,3	47	27	13	13	211





**Technical and assembly instructions**

For installation, set a bore diameter in the door, cover or hatch as shown in the outline drawing opposite. The latch housing is inserted into the installation bore from the front and secured from the back with the mounting nut. Then the latch arm is secured with the hexagon head screw.

In series production, the required installation bore in the door leaf is usually created by punching or laser cutting. The installation bore diameter can also be created by drilling or milling as shown in the outline drawings. The sheet metal punch GN 123 (see page 1493) is also available for small series production and sheet steel with a thickness < 2 mm.

Construction note for $d_i = 22$	Construction note for $d_i = 30$
Bore distance	
Installation bore for punching or lasering	
Installation bore for drilling or milling	